

## SM25-04

- Straight running belt
- Pitch 25 mm
- Belt Height: 9 mm
- Open belt, open area 18%
- Rod, plastic, steel  $\varnothing$ 5 mm
- Standard width increment: 16,66 mm
- easy to clean belt design
- hinges pin: PP, PE, POM, Steel

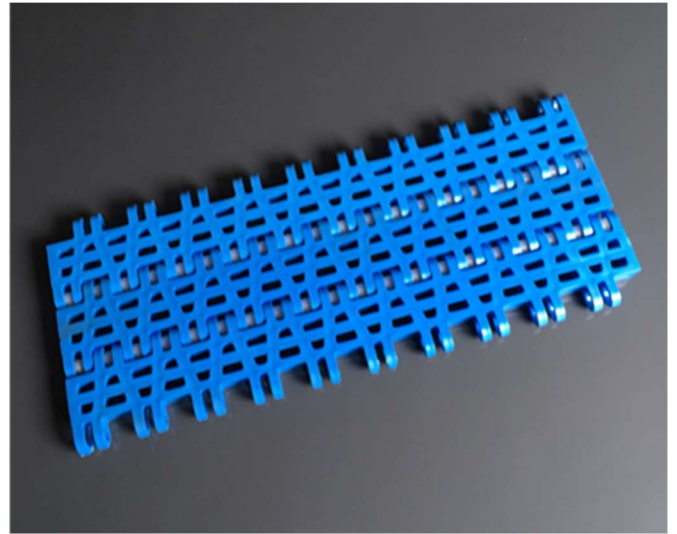

Standard material	Open area %	Maximum belt pull N/mm	Belt weight kg/m <sup>2</sup>	Standard colors
PE	32	7	4,2	White, dark blue, light blue
PP	32	11	4,2	White, dark blue, light blue
POM	32	15,5	6,2	White, dark blue, light blue

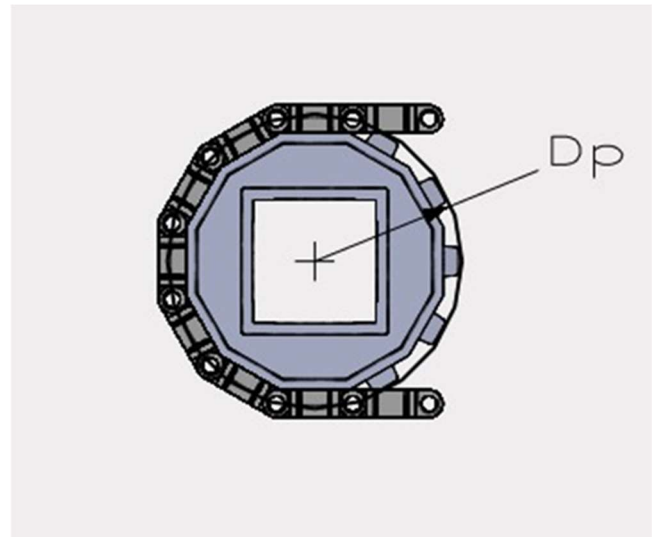

Number of teeth	Pitch diameter(Dp)	Outside diameter	Inside diameter	Round bore	Square bore	Hub width	Standard materiel
Z6	51	58,4	40,4	20	25	20	POM
Z12	96,6	105,3	87,3	25/30/40	25/40	40	POM
Z20	157,8	166,8	148,8	30/40	40	40	POM

Other bore size and teeth upon request.

## Accessories

### Flights

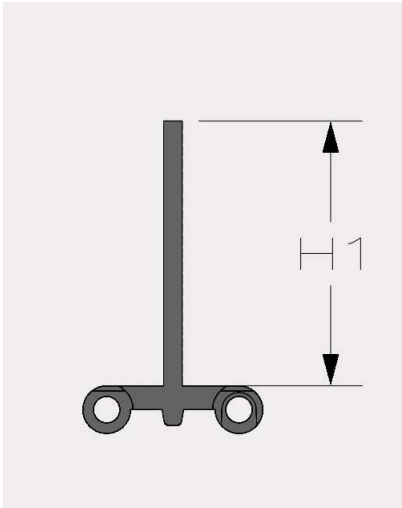

Height H1	Standard flight	Supported flight	Bent flight	Round top
3 mm	•			
25 mm	•			
50 mm	•			
75 mm				
100 mm				
150 mm				

For special applications and sizes please contact HETO-DAN for further information's.

### Side guards



25, 50 mm height

### Hold down

